

CERNIERE INOX (cod. IM)

Attenzione! Le dimensioni riportate possono subire variazioni minime a seconda del lotto di produzione.  
Si consiglia di non praticare i fori di fissaggio prima di ricevere il prodotto.

**CERNIERA A BISCOTTO PER TAVOLI - A.304**  
**Art. 8018**

Ø fori	svasatura	con spina ribadita Ø
mm	mm	mm
4,3	8	4

**CERNIERA - A.304**  
**Art. 8041**

Ø fori	svasatura	con spina ribadita Ø
mm	mm	mm
4,3	8	4

**CERNIERA - A.304**  
**Art. 8043**

Ø fori	svasatura	con spina ribadita Ø
mm	mm	mm
4,3	8	4

**CERNIERA - A.304**  
**Art. 8044**

Ø fori	svasatura	con spina ribadita Ø
mm	mm	mm
5,3	10	4

**CERNIERA ALI STONDATE TIPO A - A.304**  
**Art. 8046A**

Ø fori	svasatura	con spina ribadita Ø
mm	mm	mm
4,3	8	4

**CERNIERA ALI STONDATE TIPO B - A.304**  
**Art. 8046B**

Ø fori	svasatura	con spina ribadita Ø
mm	mm	mm
5,3	10	4

**CERNIERA ALI STONDATE TIPO C - A.304**  
**Art. 8046C**

Ø fori	svasatura	con spina ribadita Ø
mm	mm	mm
6,3	11,5	4

**CERNIERA - A.304**  
**Art. 8048**

Ø fori	svasatura	con spina ribadita Ø
mm	mm	mm
4,3	8	4

CERNIERE INOX (cod. IM)

Attenzione! Le dimensioni riportate possono subire variazioni minime a seconda del lotto di produzione.  
Si consiglia di non praticare i fori di fissaggio prima di ricevere il prodotto.

CERNIERA ALI QUADRATE TIPO A - A.304  
Art. 8047A

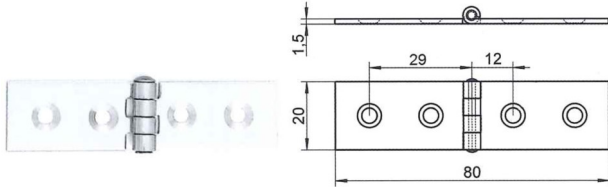

Ø fori	svasatura	con spina ribadita Ø
mm	mm	mm
4,3	8	4

CERNIERA ALI QUADRATE TIPO B - A.304  
Art. 8047B

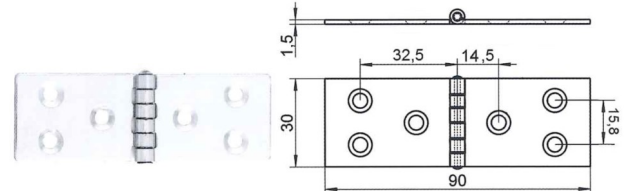

Ø fori	svasatura	con spina ribadita Ø
mm	mm	mm
5,3	10	4

CERNIERA ALI QUADRATE TIPO C - A.304  
Art. 8047C

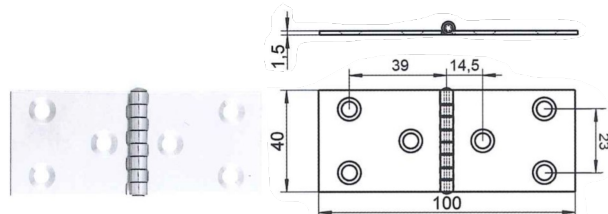

Ø fori	svasatura	con spina ribadita Ø
mm	mm	mm
6,3	11,5	4

CERNIERE A LIBRETTO - A.304  
Art. 8049

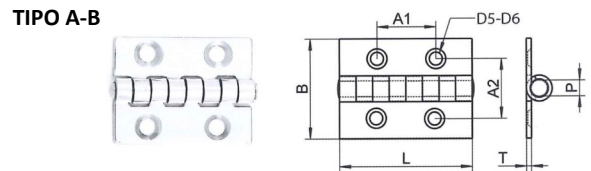

Codice	B	T	L	A1	A2	D5	D6	P RIBADITA
mm								
8049A	30	1,5	40	20	20	4,3	8	4
8049B	40	1,5	40	20	23	4,3	8	4

TIPO C-D-E

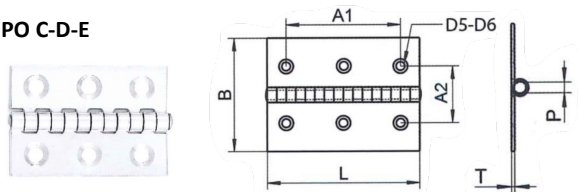

Codice	B	T	L	A1	A2	D5	D6	P RIBADITA
mm								
8049C	40	1,5	60	40	25	5,3	10	4
8049D	50	1,5	60	40	34,7	5,3	10	4
8049E	60	1,5	60	40	41	5,3	10	4

TIPO F-G-H-I

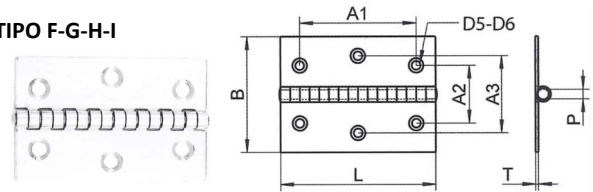

Codice	B	T	L	A1	A2	A3	D5	D6	P RIBADITA
mm									
8049F	50	1,5	80	60	24	34	5,3	10	4
8049G	60	1,5	80	60	24	44	5,3	10	4
8049H	70	1,5	80	60	27,5	47,5	5,3	10	4
8049I	80	1,5	80	60	37,5	57,5	5,3	10	4

TIPO A-B-C-D

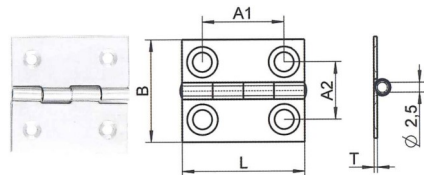

Codice	B	T	L	A1	A2	P RIBADITA
mm						
8150A	25	0,8	30	20	14	2,5
8150B	30	0,8	30	20	19	2,5
8150C	35	0,8	40	26	20	2,5
8150D	40	0,8	40	26	22	2,5

CERNIERE A LIBRO - A.304  
Art. 8150

TIPO E-F-G-H

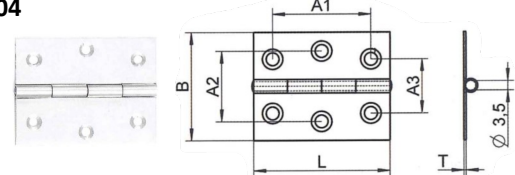

Codice	B	T	L	A1	A2	A3	P RIBADITA
mm							
8150E	40	0,8	50	36	29	21	3,5
8150F	50	0,8	50	36	40	21	3,5
8150G	50	0,8	60	45	36	25	3,5
8150H	55	0,8	70	50	40	30	3,5

CERNIERE INOX (cod. IM)

Attenzione! Le dimensioni riportate possono subire variazioni minime a seconda del lotto di produzione.  
Si consiglia di non praticare i fori di fissaggio prima di ricevere il prodotto.

CERNIERA PESANTE - A.304

Art. 8151

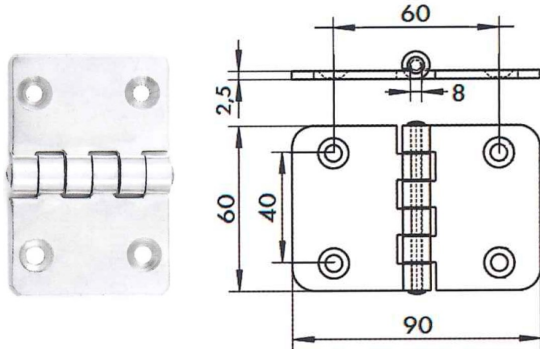

Ø fori	svasatura	con spina ribadita Ø
mm	mm	mm
5,3	11	8

CERNIERA PESANTE - A.304

Art. 8152

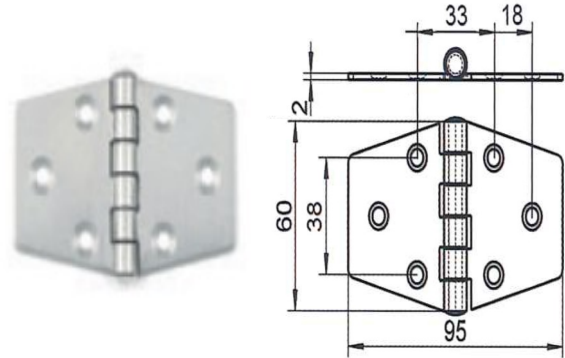

Ø fori	svasatura	con spina ribadita Ø
mm	mm	mm
5,3	10	6

CERNIERA A LIBRO MICROFUSA LUCIDA - A.316

Art. 8233

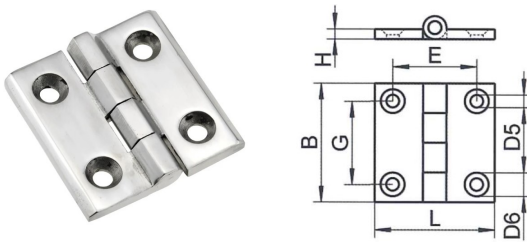

Codice	B	H	L	G	E	D5	D6
mm							
8233A	38	4,5	38	25	25	4,3	8
8233B	50	4,5	50	35	35	5,3	10

CERNIERA ASIMMETRICA MICROFUSA LUCIDA - A.316

Art. 8234

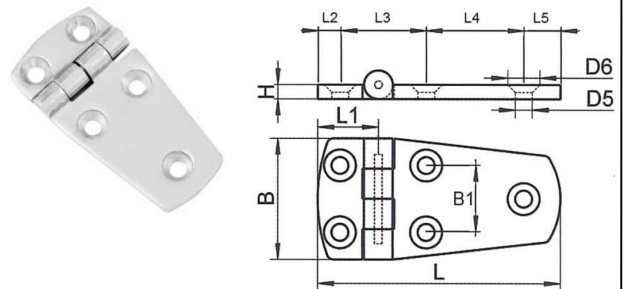

Codice	B	B1	H	L	L1	L2	L3	L4	L5	D5	D6
mm											
8234A	38	19	4,5	57	21	7,5	25	17	7,5	5,3	10
8234B	38	19	4,5	76	21	7,5	27,5	30	10,5	5,3	10

CERNIERA SFILABILE DESTRA E SINISTRA PER PORTELLINO VANO MOTORE

MICROFUSA LUCIDA - A.316

Art. 8239DX - 8239SX

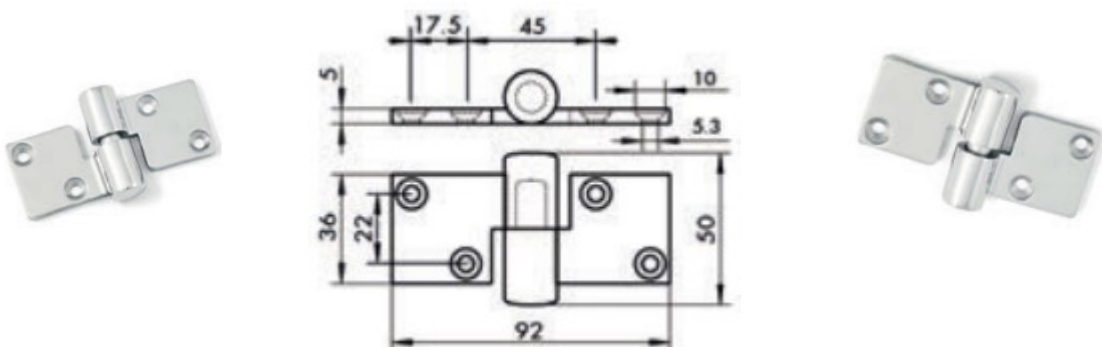

**CERNIERE INOX (cod. IM)**

Attenzione! Le dimensioni riportate possono subire variazioni minime a seconda del lotto di produzione.  
Si consiglia di non praticare i fori di fissaggio prima di ricevere il prodotto.

**CERNIERE ALI LUNGHE MICROFUSE LUCIDE - A.316**

Art. 8235A/B

TIPO A

Codice  
8235A

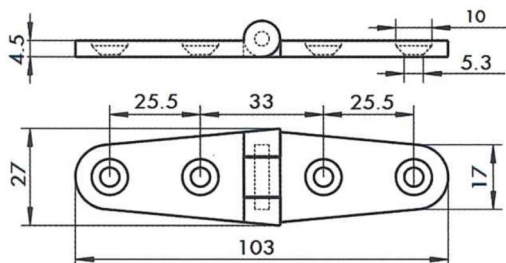

TIPO B

Codice  
8235B

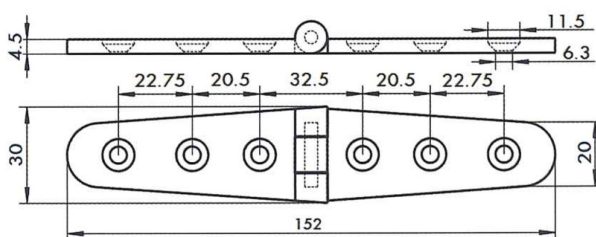

**CERNIERA A SBALZO MICROFUSA LUCIDA - A.316**

Art. 8237A/B

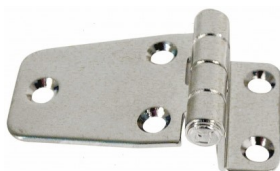

Codice	B	B1	B2	B3	H	H1	L	L1	L2	D5	D6
mm.											
8237A	37	21,5	21	25	14	4,5	54	24	18	5,3	10
8237B	37	21,5	21	25	14	4,5	68	24	32	5,3	10

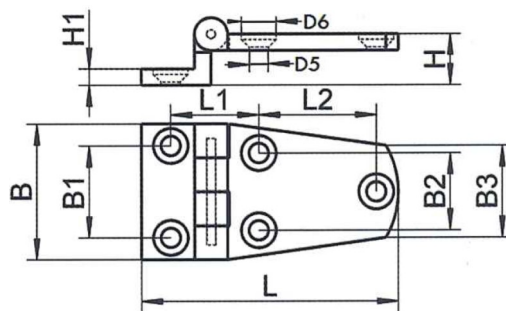

**CERNIERA PER PORTE MICROFUSA LUCIDA - A.316**

Art. 8280A/B



Codice	B	B1	B2	H	L	L1	L2	D5	D6
mm.									
8280A	38	26	19,5	4,5	76	29	13,5	5,3	10
8280B	38	29	21	4,5	102	43	13,5	5,3	10

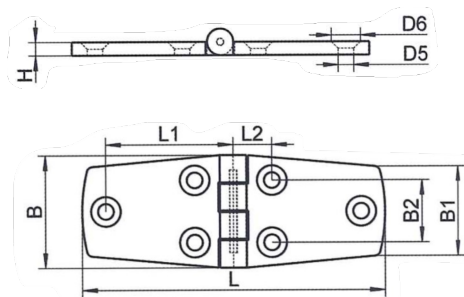



**CERNIERE INOX (cod. IBF - IM)**

Attenzione! Le dimensioni riportate possono subire variazioni minime a seconda del lotto di produzione.  
Si consiglia di non praticare i fori di fissaggio prima di ricevere il prodotto.

**CERNIERA SATINATA CON DUE CUSCINETTI A SFERA - A.316**  
Cod. IBF art. 970

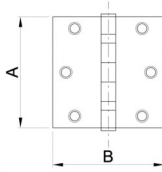

Codice	A	B
	mm	mm
9703025	76	63,5
9703030	76	76
9703530	89	76
9704030	101	76
9704035	101	89

**CERNIERA A "T" MICROFUSA LUCIDA - A.316**  
Cod. IM art. 8281

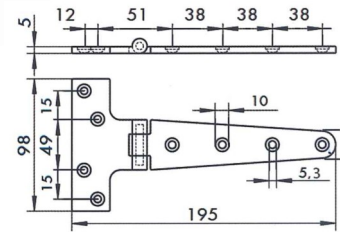

**CERNIERA EXTRA PESANTE INOX CON PERNO FISSO**  
Cod. IM art. 0846A186

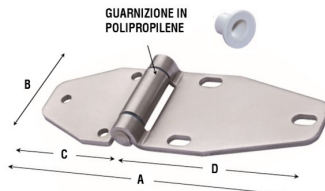

GUARNIZIONE IN POLIPROPILENE

A	B	C	D	Ø perno	Spess.
mm	mm	mm	mm	mm	mm
186	65	72	114	16	4

**CERNIERA CON COSTA DA SALDARE INOX E PERNO FISSO**  
Cod. IBF art. 0914

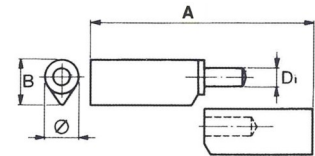

Codice	A	Ø	B	D
	mm	mm	mm	mm
0914040	40	10	12	6
0914060	60	10	12	6
0914080	80	12	14	7
0914100	100	14	16	8
0914120	120	16	18	9
★ 0914140	140	16	18	9
0914160	160	18	20	10

**CERNIERA PER SERRAMENTI CON PERNO FISSO - A.304**  
Cod. IM art. 8131

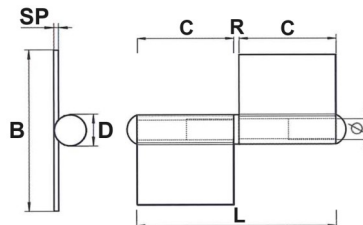

Codice	L	B	C	R	D	Sp.	Ø
	mm	mm	mm	mm	mm	mm	mm
8131060DX	62	56	30	3	14,5	2,5	9
8131060SX	62	56	30	3	14,5	2,5	9
8131080DX	82	72	40	3	14,5	2,5	9
8131080SX	82	72	40	3	14,5	2,5	9
8131100DX	102	80	50	3	17	3	10
8131100SX	102	80	50	3	17	3	10
8131120DX	122	80	60	3	17	3	10
8131120SX	122	80	60	3	17	3	10

**CERNIERA A SALDARE CON ALI PIANE E PERNO FISSO INOX**  
Cod. IM art. 1226

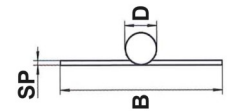
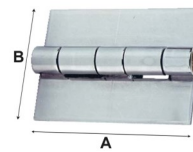

Codice	A	B	Ø cerniera	Sp.	Ø D
	mm	mm	mm	mm	mm
1226060	60	47,5	13	2,5	8
1226080	80	58	13	2,5	8
1226100	100	61	14	2,5	9

**CERNIERA A SALDARE CON PERNO FISSO - A.304**  
Cod. IM art. 8132

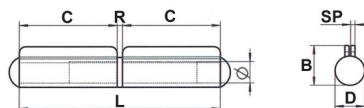

Codice	L	B	C	R	D	SP	Ø
	mm	mm	mm	mm	mm	mm	mm
★ 8132060	60	15	27	2	12	2	8
★ 8132080	77	15	37	2	12	2	8
8132100	96	18	46	2,5	14,5	2	10
8132120	120	21	55	2,5	16,5	2	10
8132140	132	21	65	2,5	16,5	2,5	11

★ = articolo soggetto a quantitativi minimi di fornitura

**CERNIERE (cod. IBF - IM - UG)**

Attenzione! Le dimensioni riportate possono subire variazioni minime a seconda del lotto di produzione.  
Si consiglia di non praticare i fori di fissaggio prima di ricevere il prodotto.

**CERNIERA PER CANCELLI A 2 ALI APERTE**  
**PERNO SFILABILE - INOX**  
Con ranella in ottone  
**Cod. IBF art. 0486A160**

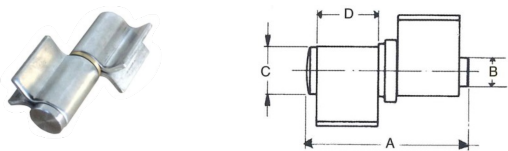

A	B	C	D
mm	mm	mm	mm
90	16	23	41

**CERNIERA PER CANCELLI A 3 ALI**  
**PERNO SFILABILE - INOX**  
**Cod. IM art. 1235**

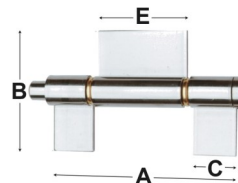

Codice	A	B	C	E	∅ cerniera	Sp.	∅ PERNO
	mm	mm	mm	mm	mm	mm	mm
1235010	107	90	25	50	21	3	14
★1235015	153	100	35	75	24	4	16
1235020	208	110	50	100	24	4	16

**CERNIERA A SALDARE A 2 ALI**  
**PERNO SFILABILE - A.304**  
Con rondella antifrizione in ottone  
**Cod. IM art. 8128**

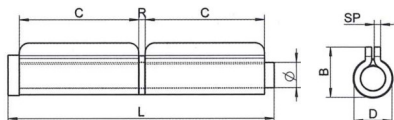

Codice	L	B	C	R	D	Sp.	∅
	mm	mm	mm	mm	mm	mm	mm
8128060	60	15	27	2	12	2	8
8128080	80	15	37	2	12	2	8
8128100	100	18	46	2,2	14,5	2	10
8128120	120	21	55	2,2	16,5	2	10
8128140	140	21	65	2,5	16,5	2,5	11

**CERNIERA A SALDARE A 3 ALI**  
**PERNO SFILABILE - A.304**  
Con rondella antifrizione in ottone  
**Cod. IM art. 8129**

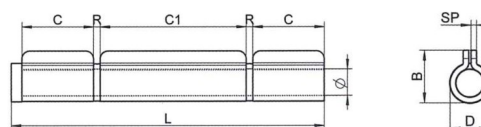

Codice	L	B	C	C1	R	D	Sp.	∅
	mm	mm	mm	mm	mm	mm	mm	mm
8129100	100	18	21,5	46	2	14,5	2	10
8129120	120	21	27	55	2	16,5	2	10
8129140	140	21	32	65	2	16,5	2	11

**CERNIERA PER SERRAMENTI CON 3 ALI PIANE**  
**E PERNO SFILABILE - A.304**  
**Cod. IM art. 8130**

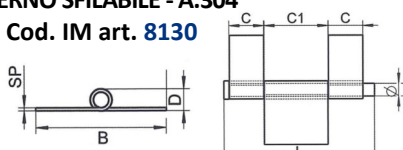

Codice	L	B	C	C1	D	Sp.	∅
	mm	mm	mm	mm	mm	mm	mm
8130110	118	87	27	49,8	14	2	10
8130140	148	96	33	67,7	18	2,5	12

**CERNIERA IN VERGHE - A.304**  
**Cod. IM art. 0027**

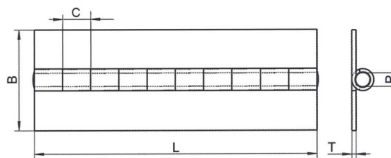

Codice	B	T	L	C	P
	mm	mm	mm	mm	mm
002701	32	0,7	1980	15	2
002702	40	0,7	1980	15	2
002703	30	1,5	1980	30	4
002704	40	1,5	1980	30	4
002705	50	1,5	1980	30	4
002706	50	2	1980	30	6
002707	60	2	1980	30	6
002708	80	3	2000	40	9
002709	100	3	2000	40	9
002710	120	3	2000	40	9

**CERNIERA IN NYLON RINFORZATA VETRO CON FORO PASSANTE**  
**Cod. UG**

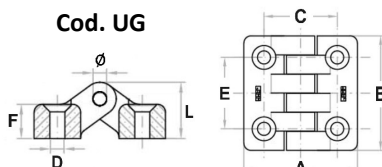

Codice	A	B	C	D	∅	E	F	L
	mm	mm	mm	mm	mm	mm	mm	mm
C40A	38,5	39,5	25	4,5	3	25	9,5	14,5
C48A	48	48	31	5,5	5	30	12,5	20,5
C65A	65	65	40	6,5	6	40	14	25
C98A	97,5	96,5	62,5	10,5	8	59,5	20,5	35

★ = articolo soggetto a quantitativi minimi di fornitura