

**RACCORDI A MANDRINARE**

Esecuzione lucida esterna / spazzolata interna in A.304L e A.316L (cod. RMM)

**CURVE a 90°, 45° e 180°**

Ricavate da tubi elettrouniti, decapati e accuratamente scordonati.

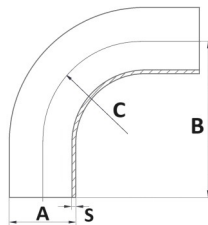

Art. 215

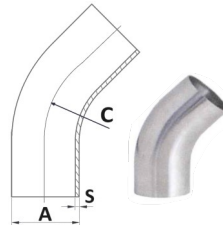

Art. 234

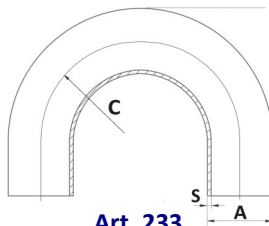

Art. 233



MISURE (mm)				
A	S	Norma	B	C
12	1,5	DIN 11852	38	26
18	1,5	DIN 11852	47	35
22	1,5	DIN 11852	52	40
25,4	1,5/1,65	SMS 1146	65	38,9
28	1,5	DIN 11852	70	50
34	1,5	DIN 11852	80	55
38,1	1,5/1,65	SMS 1146	85	57,2
40	1,5	DIN 11852	85	60
50,8	1,5/1,65	SMS 1146	110	76,2
52	1,5	DIN 11852	97	70
60	1,5	DIN 11852	110	75
63,5	1,5/1,65	SMS 1146	115	84
70	2	DIN 11852	110	80
76,1	2/2,11	SMS 1146	130	96
85	2	DIN 11852	118	90
101,6	2	DIN 11852 / SMS 1146	150	110
104	2	DIN 11852	140	100

Altre esecuzioni fornibili su richiesta:

- Finitura grezza o microbigliata
- Finitura satinata interna ed esterna
- Curve SMS calibrate con rugosità interna RA 0,5 μ (ASME BPE)

★ Versione fornibile anche con raggio 1D (una volta il diametro esterno) solo a 90°

**TEE, CROCI E PEZZI A Y**

Ricavati da tubi elettrouniti, decapati e accuratamente scordonati.

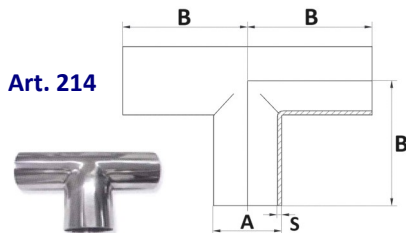

Art. 214

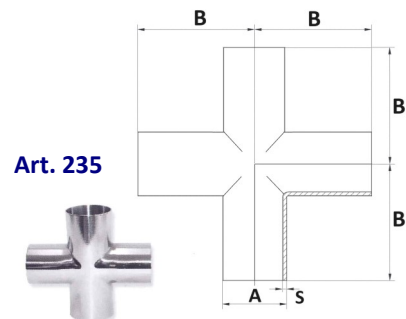

Art. 235

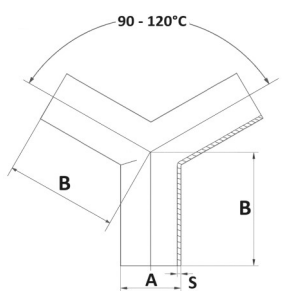

Art. 271

MISURE (mm)			
A	S	Norma	B
12	1,5	DIN 11852	26
18	1,5	DIN 11852	35
22	1,5	DIN 11852	40
25,4	1,5/1,65	SMS 1146	55
28	1,5	DIN 11852	50
34	1,5	DIN 11852	55
38,1	1,5/1,65	SMS 1146	70
40	1,5	DIN 11852	60
50,8	1,5/1,65	SMS 1146	82
52	1,5	DIN 11852	70
60	1,5	DIN 11852	75
63,5	1,5/1,65	SMS 1146	105
70	2	DIN 11852	80
76,1	2/2,11	SMS 1146	110
85	2	DIN 11852	90
101,6	2	DIN 11852 / SMS 1146	100/150
104	2	DIN 11852	100

Fornibili anche...



Tee a saldare estrusi



Curve con pezzo a "T"



Tee inclinati a 45°

Misure passibili di variazioni