

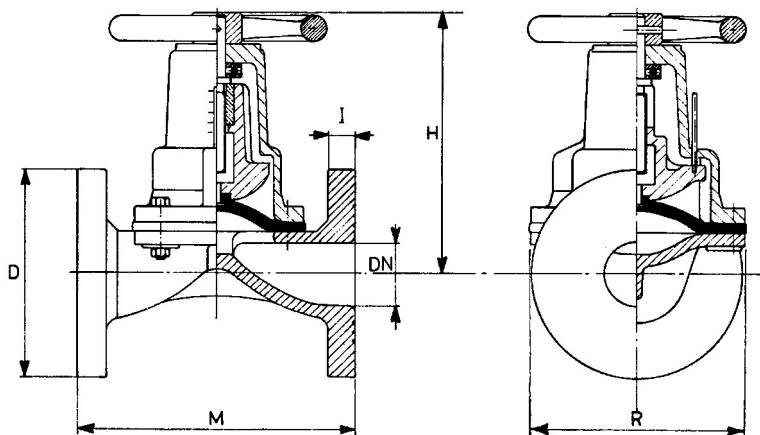

TIPO "FLAV" A MEMBRANA



CARATTERISTICHE E DIMENSIONI DEL MOD. TN 2028

DN	D	H	I	M	R	PRESSIONE MAX BAR	PESO Kg.
15	95	80	14	108	70	10	1,900
20	105	80	16	117	70	10	2,000
25	115	135	16	127	100	8	4,600
32	140	140	18	146	130	8	5,500
40	150	175	18	159	145	8	9,100
50	165	185	20	190	170	7	10,000
65	185	200	20	216	180	7	14,400
80	200	225	22	254	210	7	20,000
100	220	285	22	305	235	6	28,000
125	250	390	24	356	270	4	53,000
150	285	400	24	406	330	4	62,000
200	340	550	28	521	420	3	130,000
250	395	670	32	635	480	3	230,000
300	445	700	32	749	580	3	272,000
350	505	700	32	749	580	3	309,000

Dimensioni flange: secondo norme UNI 2223 - PN 10-16 o norme DIN 2532 - ND 10. A richiesta secondo norme ANSI 125 o 150, norme B.S. o altre norme.

Scartamento: secondo norme BS 5156 le valvole ebanitate aggiungere alla quota "M" 8 mm. dal Ø 15 al Ø 100 e 10 mm. dal Ø 125 al Ø 350.

Corpo: in ghisa o acciaio al C. con o senza rivestimento di ebanite, gomma, Hypalon. In acciaio inossidabile tipo AISI 304-316.

Membrana: in elastomeri sintetici o in PTFE.

CARATTERISTICHE E DIMENSIONI DEL MOD. TN 2028A

DN	D	H	I	M	R	PRESSIONE MAX BAR	PESO Kg.
15	95	80	14	130	70	10	2,300
20	105	80	16	150	70	10	2,500
25	115	135	16	160	100	8	5,400
32	140	140	18	180	130	8	7,000
40	150	175	18	200	145	7	11,000
50	165	185	20	230	170	7	13,500
65	185	200	20	290	180	7	17,000
80	200	225	22	310	210	7	26,000
100	220	285	22	350	235	6	35,500
125	250	390	24	400	270	4	60,000
150	285	400	24	480	330	4	70,000
200	340	550	28	600	420	3	143,000
250	395	670	32	730	480	3	230,000
300	445	700	32	850	580	3	330,000
350	505	700	32	980	580	3	345,000

TIPO LUNGO

Dimensioni flange: secondo norme UNI 2223 - PN 10-16 o norme DIN 2532 - ND 10. A richiesta secondo norme ANSI 125 o 150, norme B.S. o altre norme.

Scartamento: secondo norme DIN 3202 F1.

Corpo: in ghisa o acciaio al C. con o senza rivestimento di ebanite, gomma, hypalon. In acciaio inossidabile tipo AISI 304-316.

Membrana: in elastomeri sintetici o in PTFE.

Anche versioni filettate

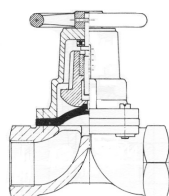

E con attuatori pneumatici.

